

Dealer _____

Key

standard

option

QUASAR

QUASAR FIX

QUASAR ADJ

- | | | |
|-----------------------------------|---|----|
| L Seat width | <input type="checkbox"/> 34 <input type="checkbox"/> 36 <input type="checkbox"/> 38 <input type="checkbox"/> 40 <input type="checkbox"/> 42 <input type="checkbox"/> 44 | |
| P Seat depth | <input type="checkbox"/> 36 <input type="checkbox"/> 38 <input checked="" type="checkbox"/> 40 <input type="checkbox"/> 42 <input type="checkbox"/> 44 <input type="checkbox"/> 46 | |
| HS Back-rest height | <input type="checkbox"/> 27 <input type="checkbox"/> 29 <input type="checkbox"/> 31 <input type="checkbox"/> 33 <input type="checkbox"/> 35 <input type="checkbox"/> 37 <input type="checkbox"/> 39 <input type="checkbox"/> 41 | |
| HA Front seat/floor height | <input type="checkbox"/> 46 <input type="checkbox"/> 48 <input type="checkbox"/> 50 | |
| HP Rear seat/floor height | <input type="checkbox"/> 40 <input type="checkbox"/> 42 <input type="checkbox"/> 44 <input type="checkbox"/> 46 <input type="checkbox"/> 48 | |
| DP Foot-rest/seat distance | <input type="checkbox"/> 37 <input type="checkbox"/> 39 <input type="checkbox"/> 41 <input type="checkbox"/> 43 <input type="checkbox"/> 45 <input type="checkbox"/> 47 <input type="checkbox"/> 49 | cm |

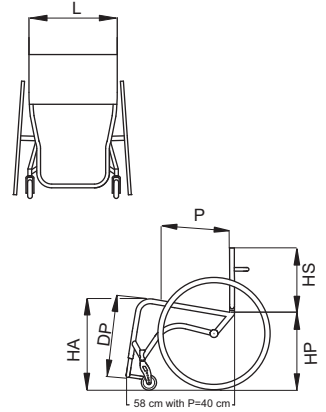

Frame colour

- | | | |
|---|--|---------------------------------------|
| <input type="checkbox"/> Shiny titanium | <input type="checkbox"/> Pearl white | <input type="checkbox"/> Glossy black |
| <input type="radio"/> Sage green | <input type="radio"/> Water green | <input type="radio"/> Antique gold |
| <input type="radio"/> Avio blue | <input type="radio"/> Potassium light purple | <input type="radio"/> Pearl grey |
| <input type="radio"/> (see "Colours" catalogue) | | |

①

Upholstery

②

- Tension adjustable nylon back-rest
 Tension adj. breathable back-rest
 Without back-rest

Single tubular titanium foot-plate

③

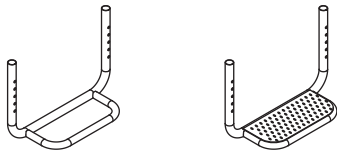

- Open
 Closed in carbon fibre

Pushing handles

④

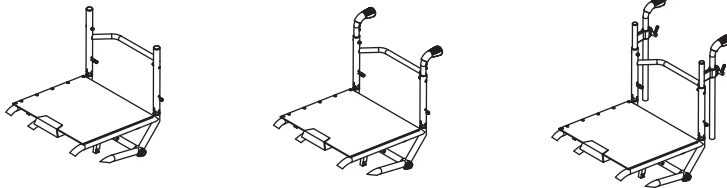

- Without pushing handles
 Standard pushing handles
 Height adjustable pushing handles

Distance between the hub centre and back-rest

⑤

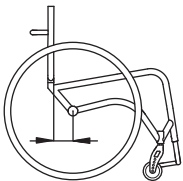

- | | |
|---|--------------------------------|
| <input type="checkbox"/> 9 cm (standard) | <input type="checkbox"/> 7 cm |
| <input type="checkbox"/> 0 cm (biamputated) | <input type="checkbox"/> 11 cm |
| <input type="checkbox"/> 3 cm | <input type="checkbox"/> 13 cm |
| <input type="checkbox"/> 5 cm | |

Back-rest tilt

⑥

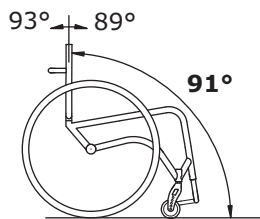

- 89°
 91° (standard)
 93°

Front angle

⑦

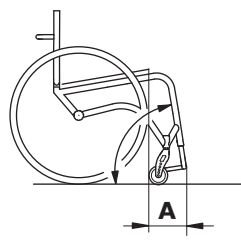

- 78° (standard) (A = 16 cm)
 70° (A = 23 cm)

Rear wheel camber

⑧

- | | |
|-----------------------------|-----------------------------|
| <input type="checkbox"/> 1° | <input type="checkbox"/> 2° |
| <input type="checkbox"/> 3° | <input type="checkbox"/> 4° |

Side guards

⑨



- Aluminium with carbon fibre wing
 Straight aluminium

Brakes

⑩

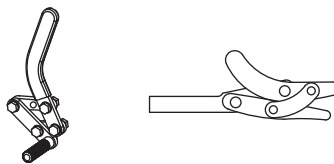

- Push brake (std)
 Scissor brake
 Pull brake

Revolving anti-tip device

⑪

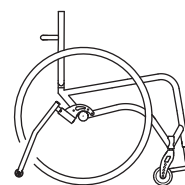

- Right
 Left

Notes

